

999016121

L.24 12/03/03
L.25
L.26

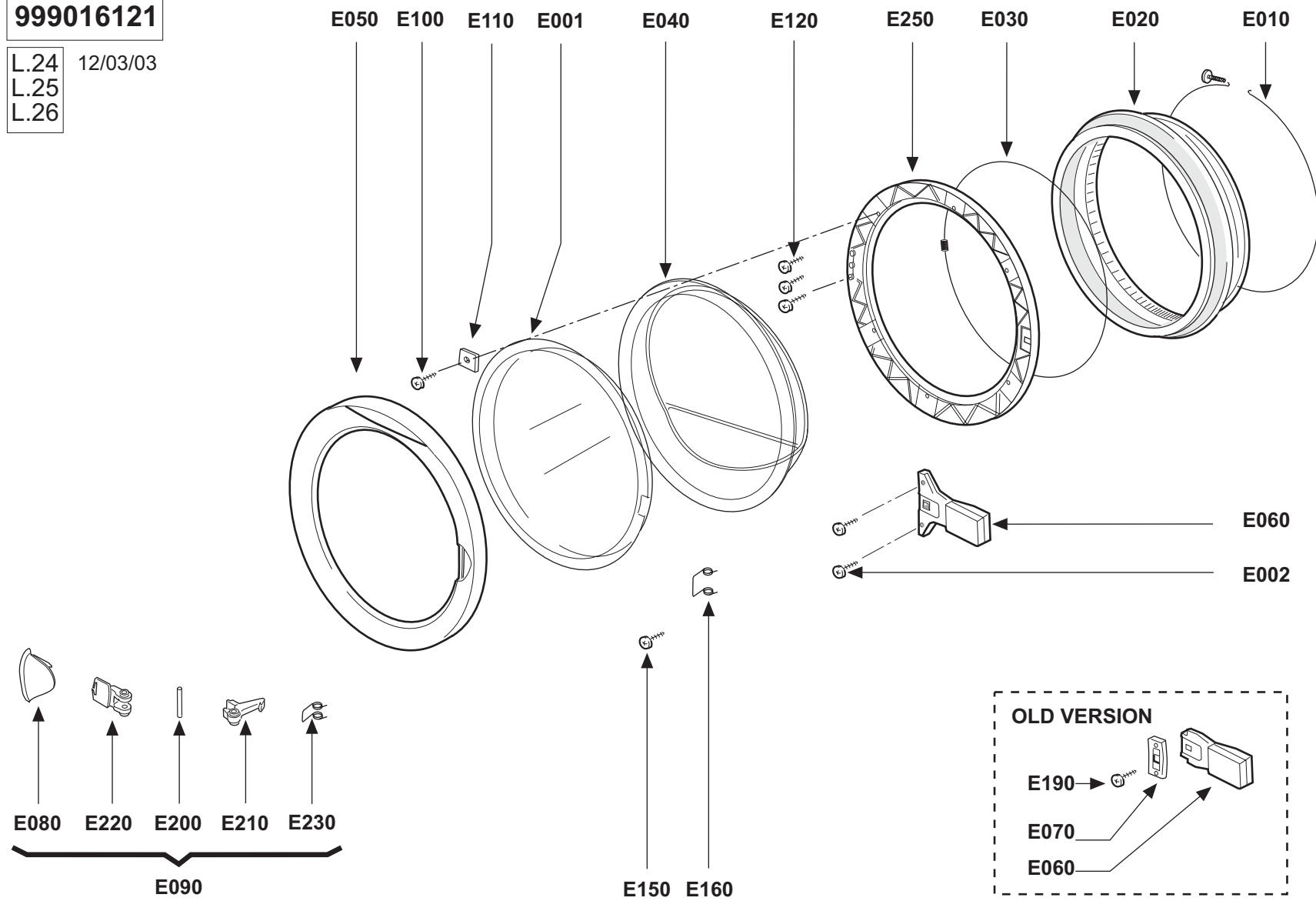

999016228

SHRINK PACKING FREE-STANDING

14/09/2006

Z290

Z310

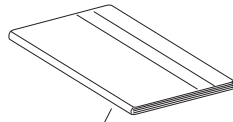

Z330
INSTRUCTIONS
FOR USE

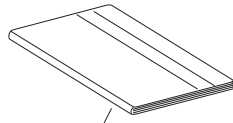

Z025
TECHNICAL DATAS
BOOKLET

Z300

Z024

Z280

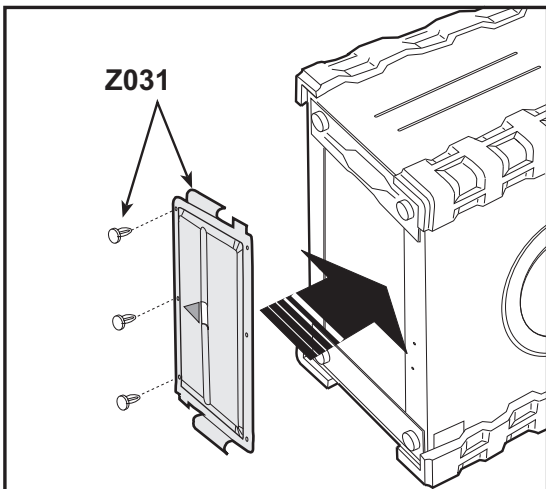

**Used only for Washing Machines
33 and 39 cm depth**

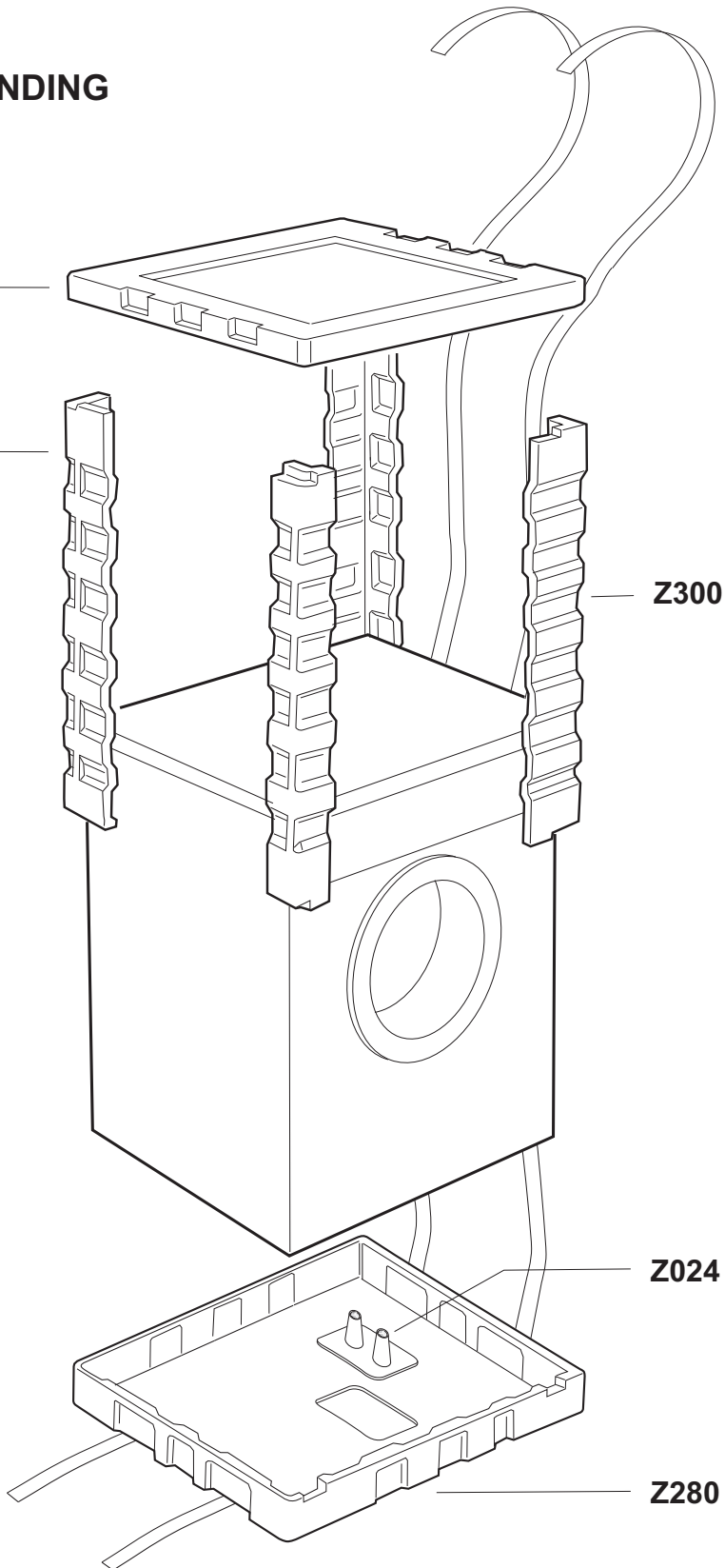

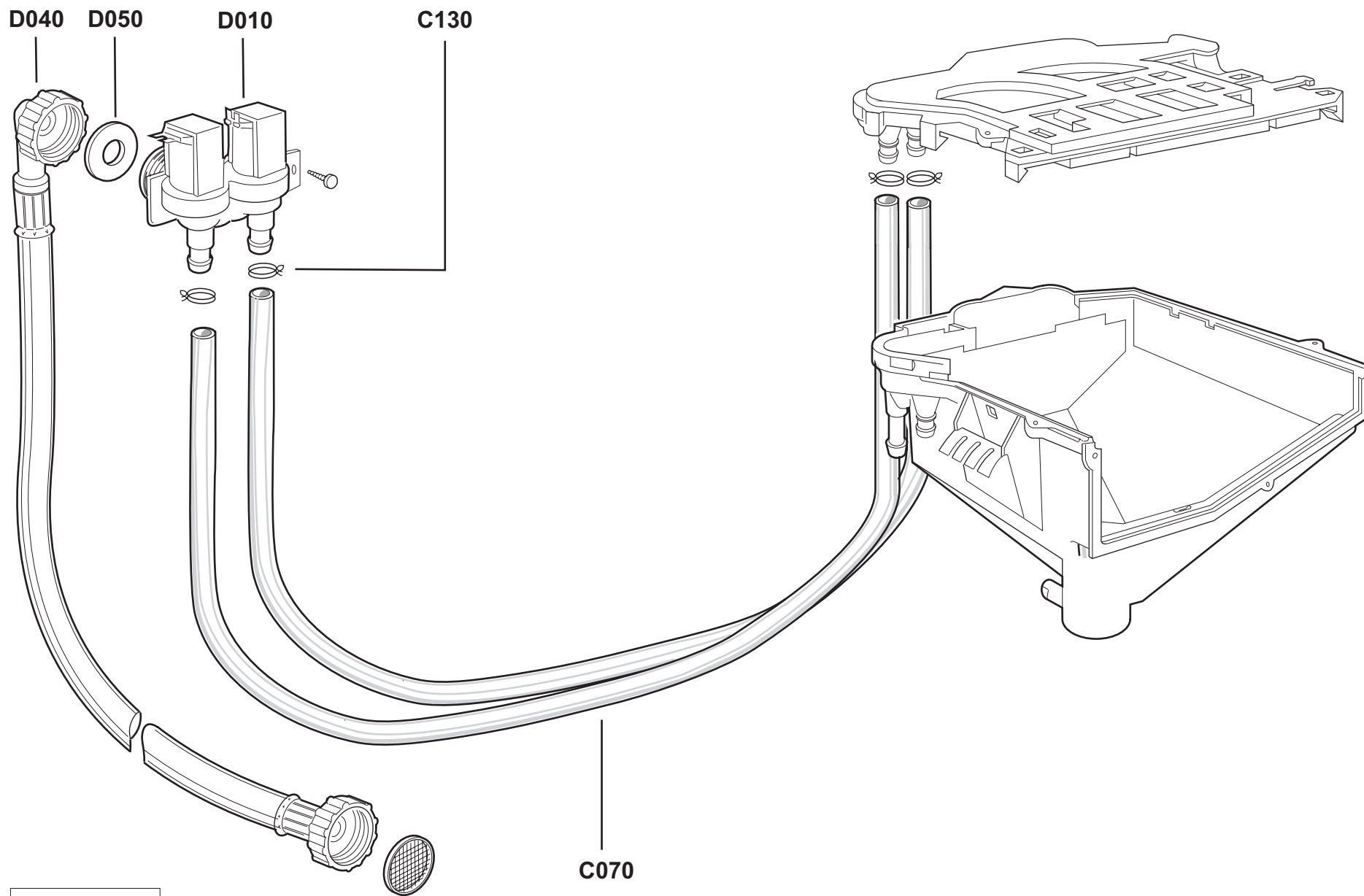

999043304

LBCF - 2 ELETTROVALVOLE
AF-ELECTRONIC
09/03/2007

999045206

LB-CFE 47lt PP
Panel "T"
26/10/2007

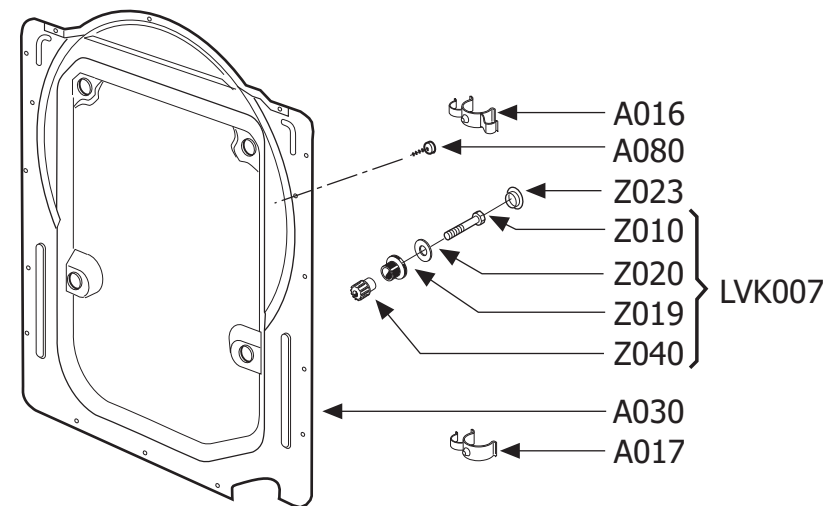
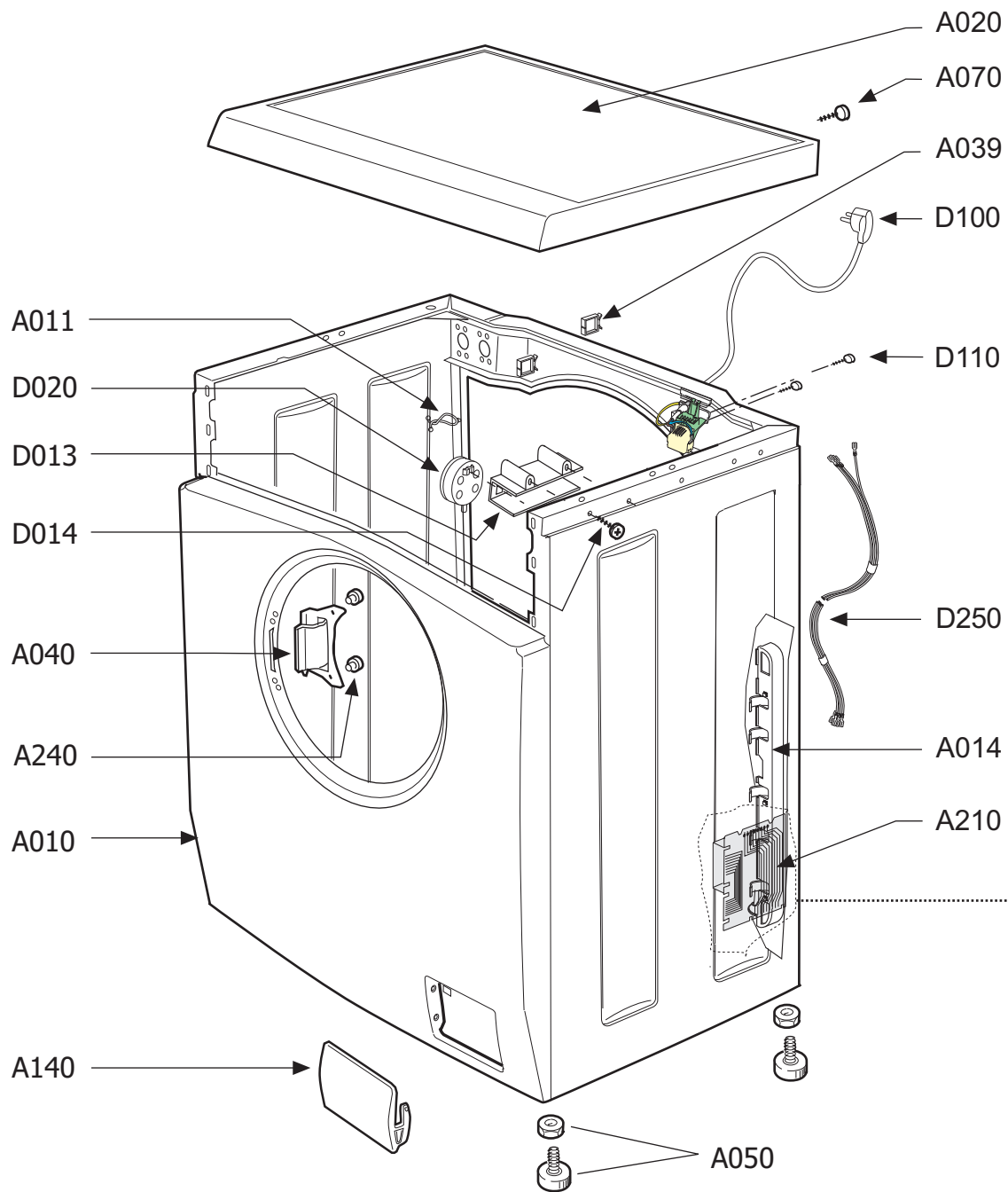

LVK007

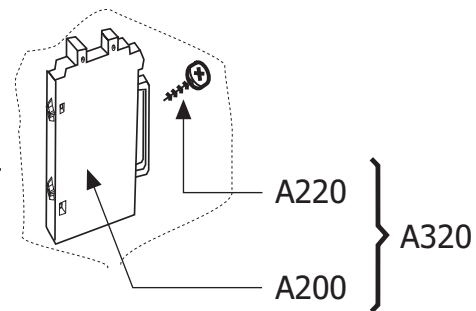

999045208

CFE with 2 Water Valve
Control panel:
CD-CE-CL-CM-CN-CR
09/03/2007

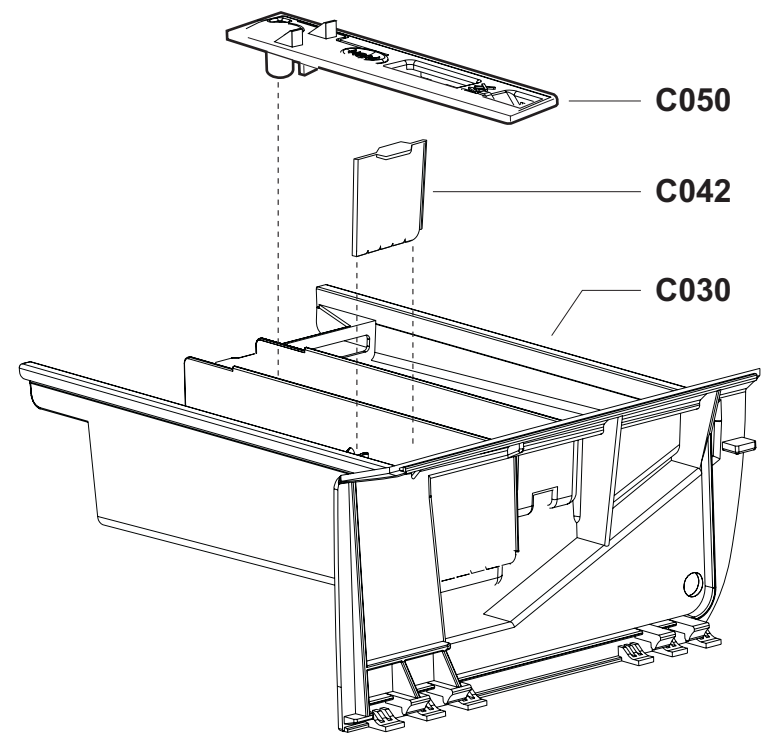
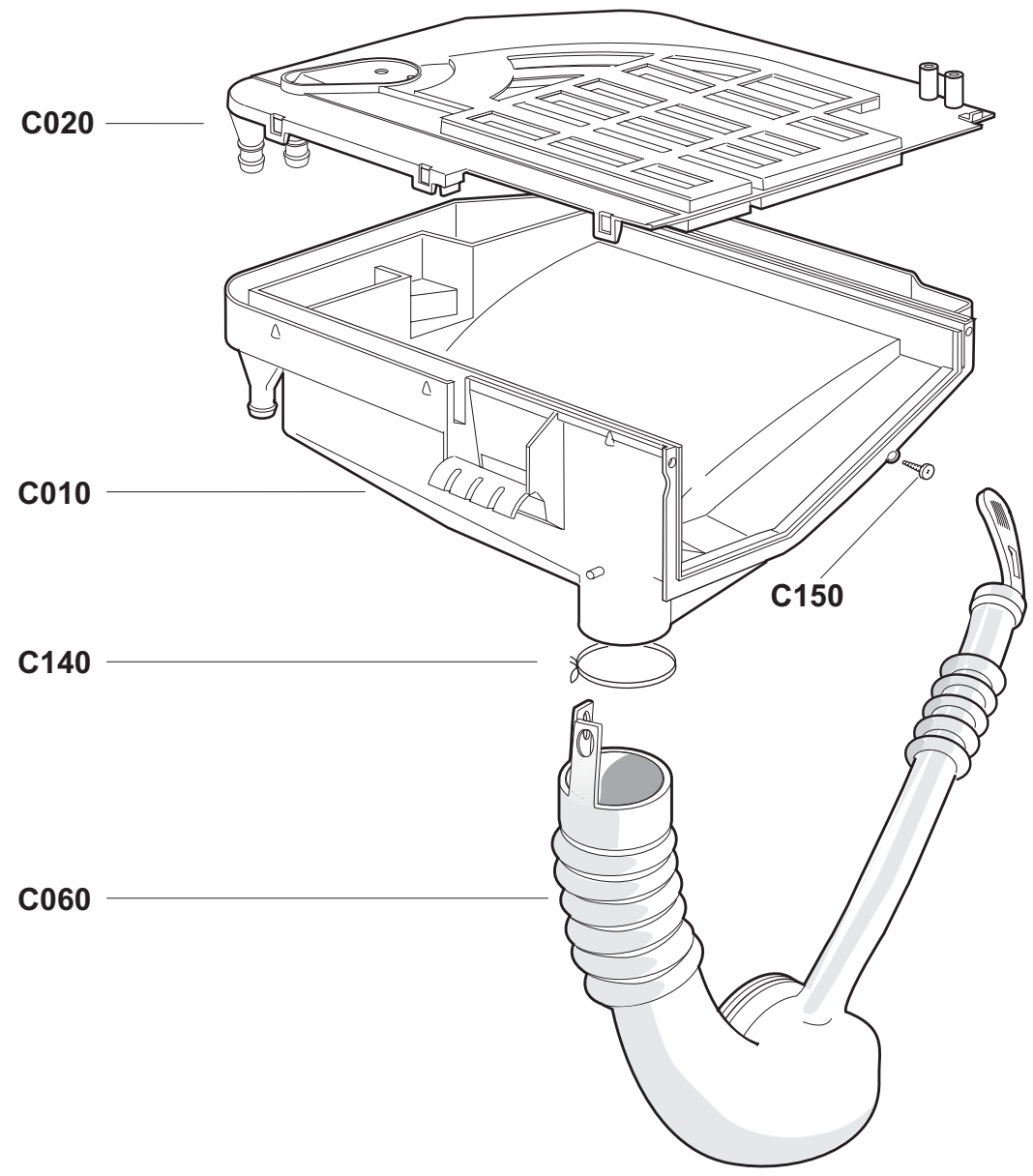

999046236

LBCF - LBAS
Collector Motor
17/01/2006

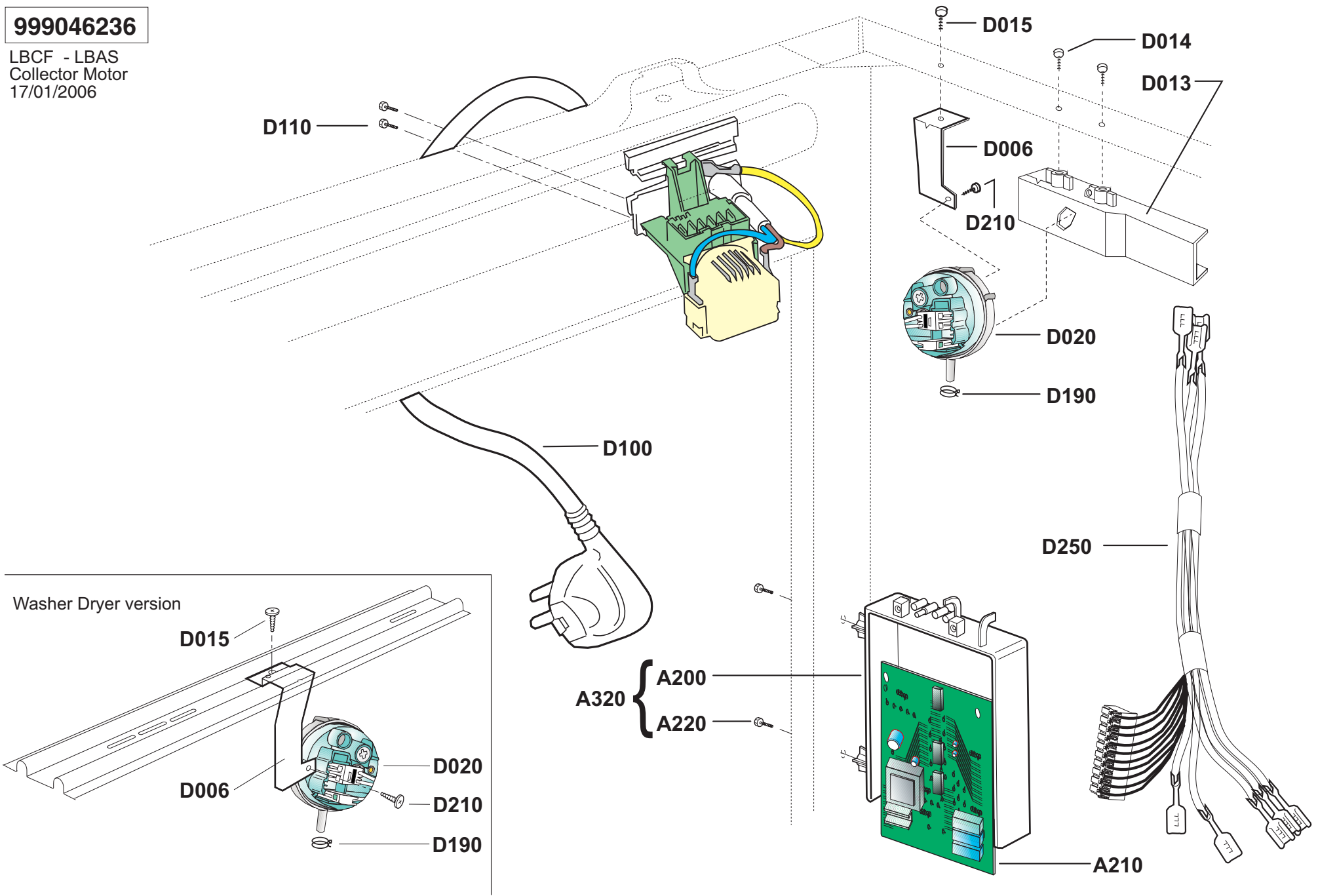

999046261

LBCF ECOCARBON
33A - 40A - 47A - 54A - 64A
12/07/2007

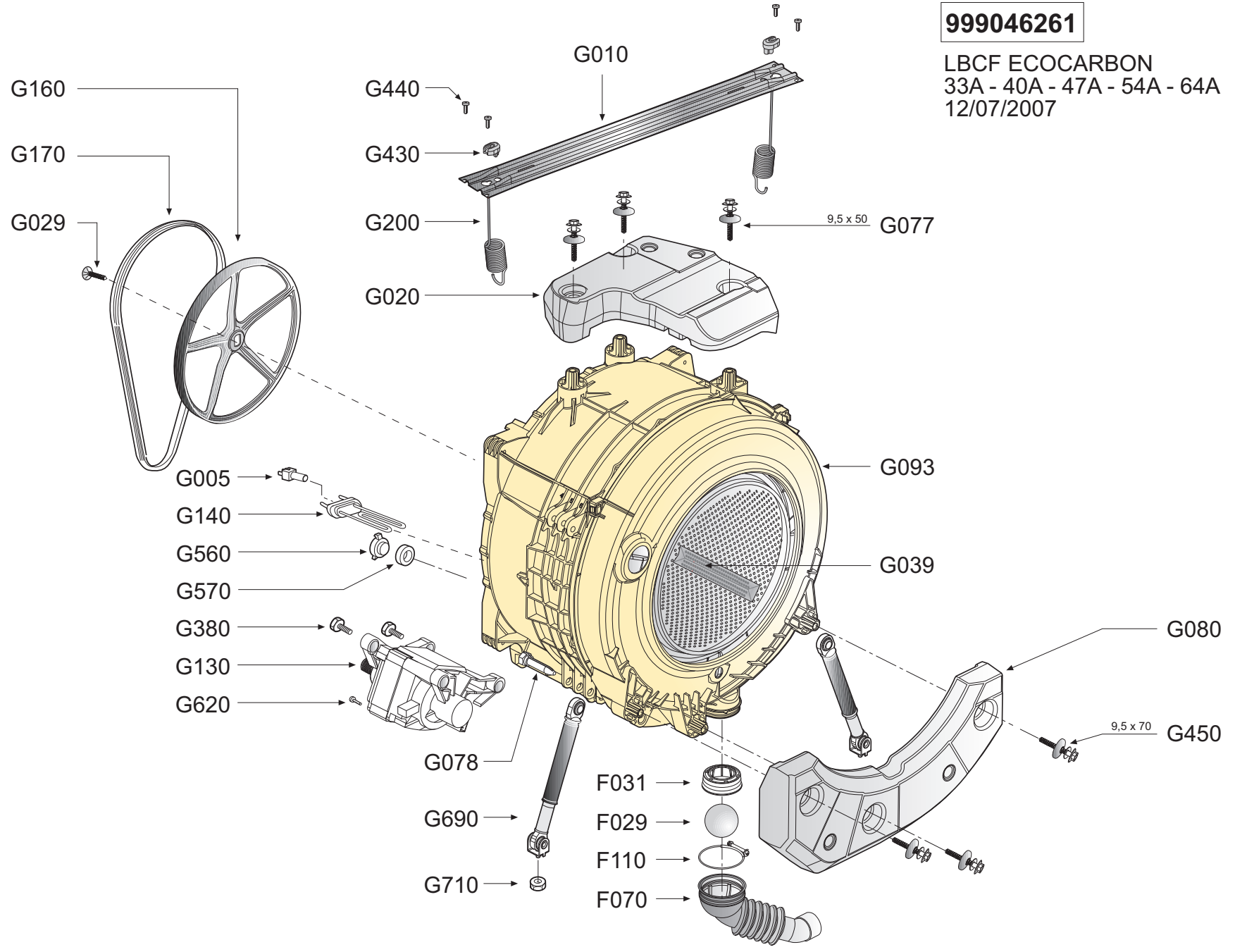

999046356

CO-CFE DISPLAY 7P 1M

04/04/2007

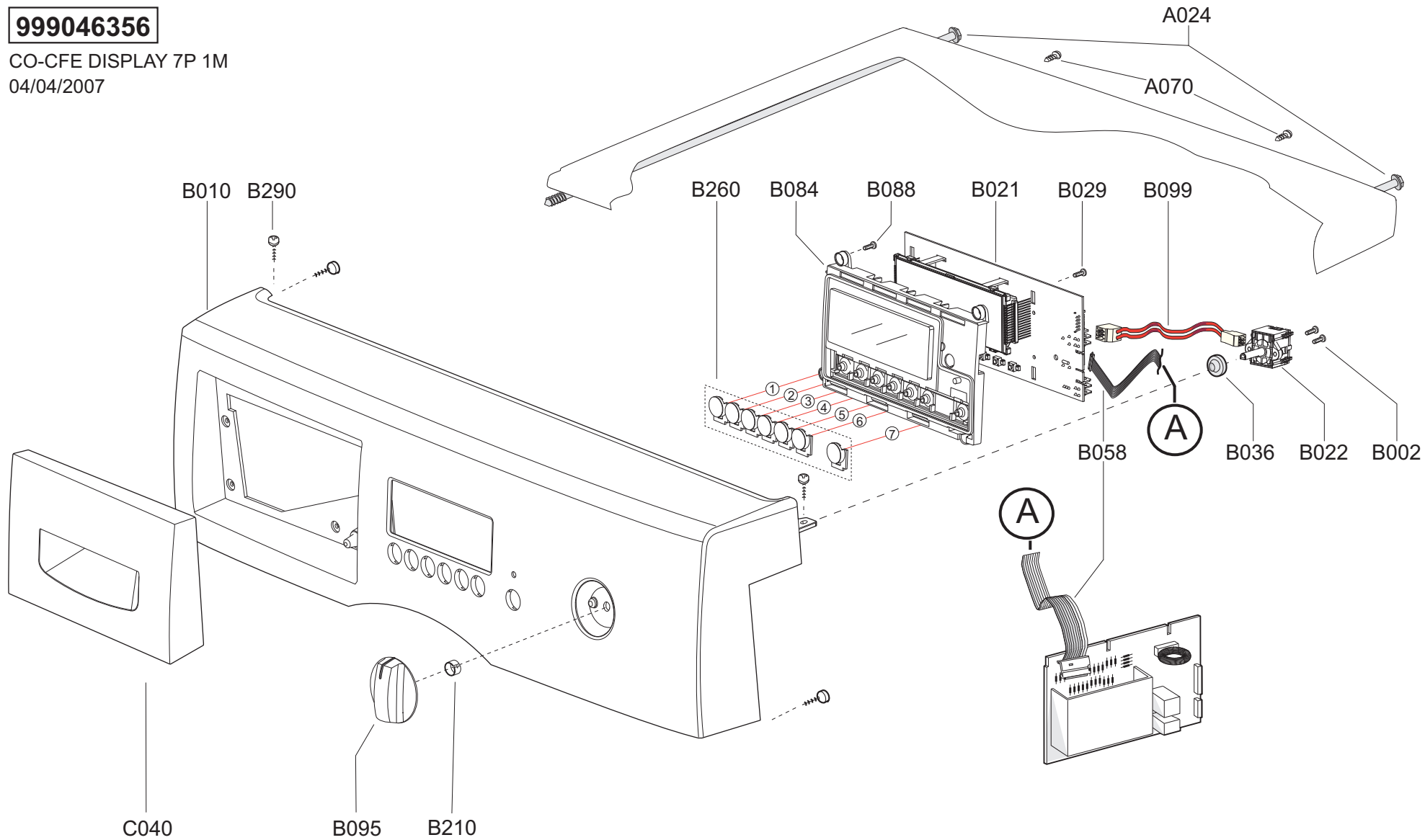

999046361

Eco-Ball & Self cleaning
drain pump system
LBCF 33A-40A-47A
26/10/2007

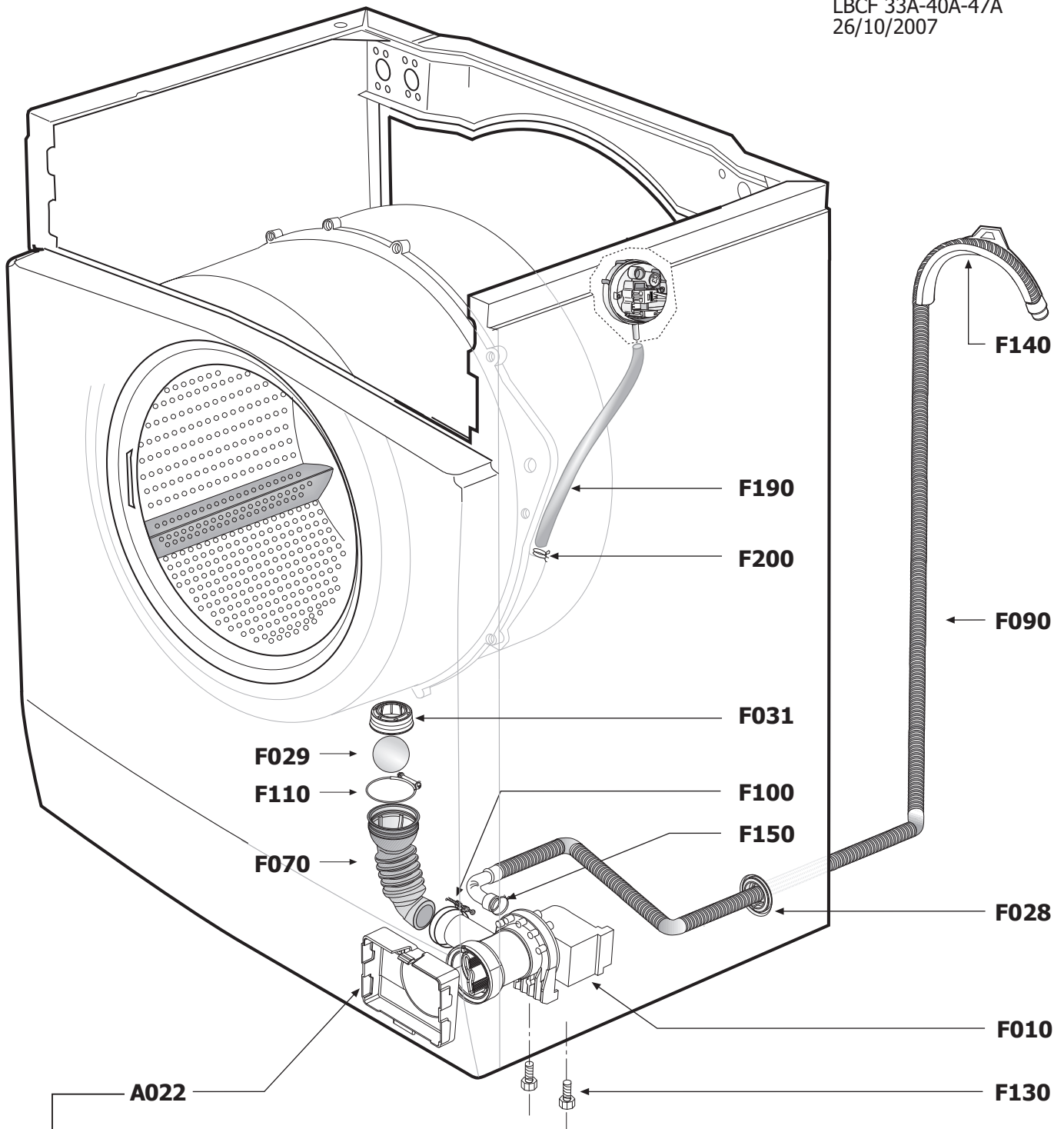

- I** → Protezione Pompa utilizzata esclusivamente su macchine provviste di Pannello frontale "T".
- F** → Protection Pompe de vidange utilisée exclusivement dans les machines ayant le Panneau frontal "T".
- GB** → Pump Cover used exclusively on machines fitted with "T" type cabinet front Panel.
- D** → Pumpenschutz ausschließlich an Maschinen mit Frontpaneel "T".
- E** → Protección Bomba utilizada exclusivamente en máquinas dotadas de Panel frontal "T".

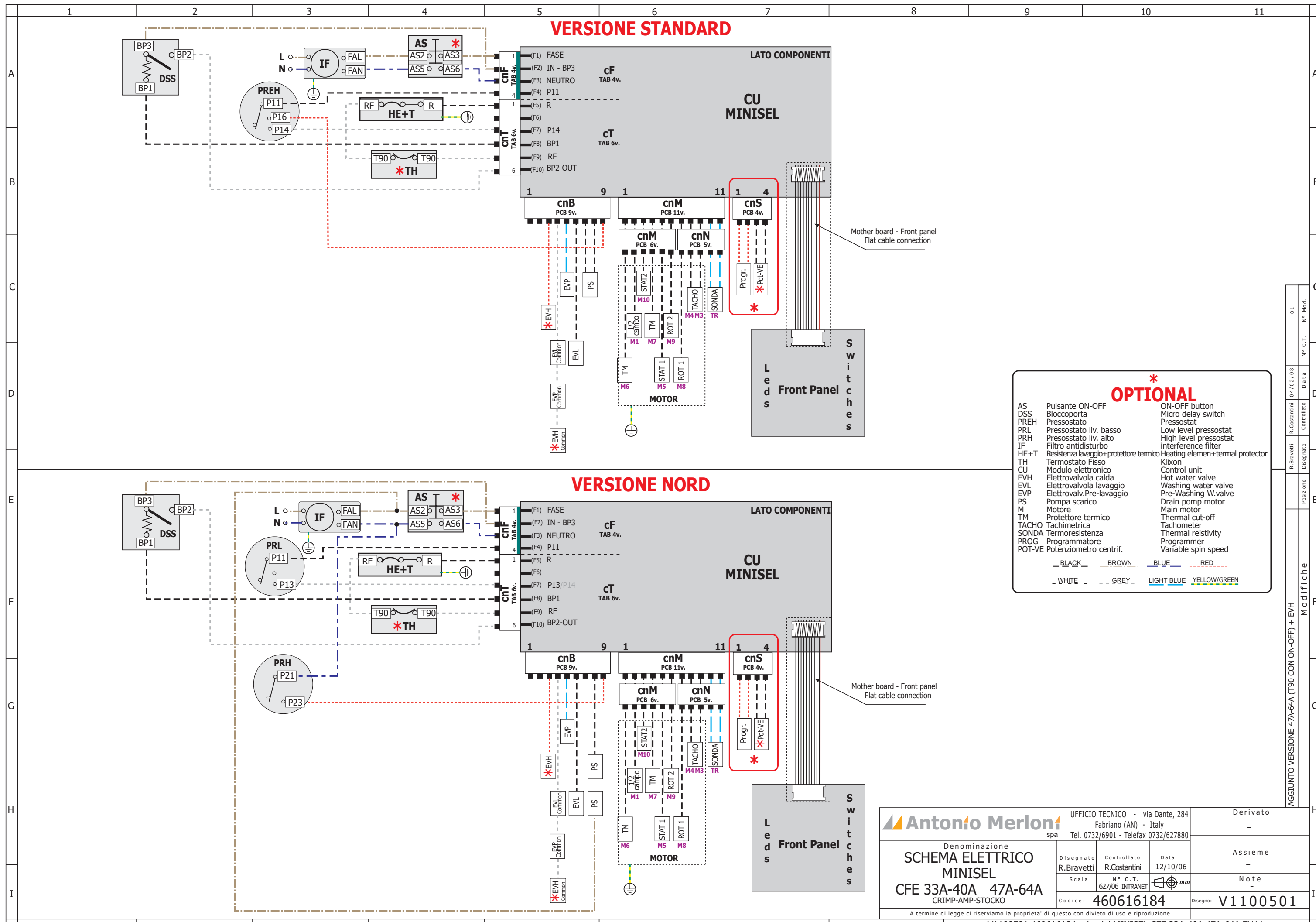

01 N° Mod.
 04/02/08 N° C.T. Data
 R.Costantini Controllato
 R.Bravetti Disegnato
 Posizione

Antonio Merloni spa UFFICIO TECNICO - via Dante, 284 Fabriano (AN) - Italy Tel. 0732/6901 - Telefax 0732/627880			Derivato -
Denominazione SCHEMA ELETTRICO MINISEL CFE 33A-40A 47A-64A CRIMP-AMP-STOCKO			Assieme -
Disegnato R.Bravetti	Controllato R.Costantini	Data 12/10/06	Note -
Codice: 460616184			Disegno: V1100501

Maschine 010576035 Eudora WAS616					
Ersatz.	Pos	Beschreibung	Laufzeit		Men
432028100	A009	BEFESTIGUNGSSCHRAUBEN HAKEN SCHLAUCH ELEKTROVENTIL	01/01/1900	21/03/2007	1
710090701	A010	GEHAEUSE	01/01/1900	31/12/4999	1
398034000	A011	SENKEL HAKEN VERKABELUNG	01/01/1900	19/07/2006	2
354023800	A014	VERTIKALE HALTERUNG SITZ VERKABELUNG	01/01/1900	31/12/4999	1
398114700	A016	SCHLAUCHBEFESTIGER ZUFLUSS-ABFLUSS WASSER GESCHLOSSEN	01/01/1900	31/12/4999	2
398027000	A017	SCHLAUCHBEFESTIGER ZUFLUSS-ABFLUSS WASSER OFFEN	01/01/1900	31/12/4999	2
721083500	A020	OBERER DECKEL	01/01/1900	31/12/4999	1
352015400	A022	SCHUTZVORR. ABSAUGPUMPE	01/01/1900	31/12/4999	1
432032400	A024	SCHRAUBE OBERER DECKEL-STIRNBRETT	01/01/1900	31/12/4999	2
276006701	A030	RUCKWARTIGER DECKEL	01/01/1900	31/12/4999	1
398108000	A039	CLIP DRAHTFIXIERUNG MAGNETVENTIL	01/01/1900	31/12/4999	3
246031700	A040	SCHARNIER	01/01/1900	31/12/4999	1
720168500	A050	FUSS REGULIERBAR	01/01/1900	31/12/4999	4
432004900	A070	SCHRAUBE FUER OBEREN DECKEL	01/01/1900	28/04/2003	2
432028400	A070	SCHRAUBE FUER OBEREN DECKEL	28/04/2003	31/12/4999	2
398091100	A080	SCHRAUBE FUER RUECKWARTIGEN DECKEL	19/10/2001	21/03/2007	1
432004600	A080	SCHRAUBE FUER RUECKWARTIGEN DECKEL	01/01/1900	19/10/2001	10
432028100	A080	SCHRAUBE FUER RUECKWARTIGEN DECKEL	21/03/2007	31/12/4999	10
398263300	A140	FILTERKLAPPE	01/01/1900	31/12/4999	1
368033100	A200	KARTENBEHALTER	01/01/1900	31/12/4999	1
546099900	A210	ELEKTRONIK-MODUL	01/01/1900	31/12/4999	1
432004900	A220	BEFESTIGUNGSSCHRAUBE F.KARTENBEHALTER	01/01/1900	02/02/2004	2
432028400	A220	BEFESTIGUNGSSCHRAUBE F.KARTENBEHALTER	02/02/2004	31/12/4999	2
438001800	A240	NIETE F.SICHTFENSTERSCHARNIER	01/01/1900	31/12/4999	4
720399600	A320	MODULTRAGER-GEHAUSEINHEIT	01/01/1900	31/12/4999	1
432003200	B002	FESTSTELLSCHRAUBE POTENTIOMETER	01/01/1900	31/12/4999	2
804660809	B010	BLENDRAHMEN	01/01/1900	31/12/4999	1
720542100	B021	ELEKTRONIKKARTE TASTEN+DISPLAY	01/01/1900	31/12/4999	1
502050300	B022	PROGRAMMSCHALTER	01/01/1900	31/12/4999	1
432026000	B029	FESTSTELLSCHRAUBE ELEKTRONIKKARTE	01/01/1900	31/12/4999	5
402027300	B036	DICHTUNG FUER POTENTIOMETER	01/01/1900	31/12/4999	1
510227700	B058	FLACHKABEL FUER ANSCHLUSS KARTE TASTENKREIS-ELEKTR. MODUL	01/01/1900	31/12/4999	1
352015500	B084	SCHUTZVORR. DISPLAY LCD	01/01/1900	31/12/4999	1
326161800	B095	POTENTIOMETER TIMER KNOPF	01/01/1900	31/12/4999	1
444005700	B210	FEDER FUER THERMOSTATKNOPF	01/01/1900	31/12/4999	1
332079400	B260	DRUCKTASTE	01/01/1900	31/12/4999	1
432004600	B290	SCHRAUBE Z.BEFESTIGUNG D.BLENDE	01/01/1900	29/03/2005	4
432010000	B290	SCHRAUBE Z.BEFESTIGUNG D.BLENDE	29/03/2005	12/04/2006	4

Maschine 010576035 Eudora WAS616					
Ersatz.	Pos	Beschreibung	Laufzeit		Men
432028100	B290	SCHRAUBE Z.BEFESTIGUNG D.BLENDE	12/04/2006	31/12/4999	4
348006000	C010	WASCHMITTEL-BEHALTER	01/01/1900	31/12/4999	1
330116900	C020	WASCHMITTEL-DECKEL-BEHALTER	01/01/1900	31/12/4999	1
398308700	C030	WASCHMITTELBEHAELTER	01/01/1900	31/12/4999	1
398233100	C042	SCHOTT FUER WASCHMITTELBEHAELTER	01/01/1900	31/12/4999	1
398233800	C050	GITTER EINSPUELKAMMER WEICHSPUELER	01/01/1900	31/12/4999	1
402039800	C060	MUFFE WASCHMITTEL EINSPUELUNG	01/01/1900	31/12/4999	1
414002500	C070	ZUFUHRUNGSSCHLAUCH	01/01/1900	08/04/2008	2
414016300	C070	ZUFUHRUNGSSCHLAUCH	08/04/2008	31/12/4999	2
440000200	C130	SCHELLE F.VERSORGUNGSSCHLAUCH	01/01/1900	31/12/4999	4
440000600	C140	MUFFENSCHELLE F. WASCHMITEINSPULUNG	01/01/1900	31/12/4999	1
432031200	C150	SCHRAUBE FUER WASCHMITTELBEHALTER	01/01/1900	31/12/4999	4
534009600	D010	ELEKTROVENTIL	01/01/1900	31/12/4999	1
352016600	D013	FIXIERGEHAEUSE DRUCKWAECHTER	01/01/1900	31/12/4999	1
432009400	D014	FESTSTELLSCHRAUBE GEHAEUSE DRUCKWAECHTER	01/01/1900	31/12/4999	2
520009700	D020	DRUCKWACHTER	01/01/1900	31/12/4999	1
408003100	D040	SCHLAUCHZULAUF	01/01/1900	31/12/4999	1
402009100	D050	DICHTUNG FUER ZULAUFSCHLAUCH	01/01/1900	31/12/4999	1
508027200	D100	NETZANSCHLUSSKABEL	01/01/1900	31/12/4999	1
432028100	D110	ERDUNGSSCHRAUBE	29/03/2006	04/12/2007	2
432032200	D110	ERDUNGSSCHRAUBE	01/01/1900	29/03/2006	2
432032200	D110	ERDUNGSSCHRAUBE	04/12/2007	31/12/4999	2
402003900	D280	FILTERDICHTUNG F.ZULAUFSCHLAUCH	01/01/1900	25/02/2007	1
432012600	E002	SCHRAUBE ZUR FIXIERUNG TUERVERRIEGELUNG AN MOEBEL	01/01/1900	31/12/4999	2
444023400	E010	RING MIT SCHRAUBE FUER BALGENDICHTUNG	01/01/1900	31/12/4999	1
404002800	E020	FENSTERMANSCHETTE	01/01/1900	31/12/4999	1
441034000	E030	SPANNRING FUER FENSTERMANSCHETTE	01/01/1900	31/12/4999	1
493103500	E040	SICHTFENSTERGLAS	01/01/1900	31/12/4999	1
338004800	E050	SICHTFENSTER RAHMEN	01/01/1900	31/12/4999	1
530001500	E060	TUERSCHALTER	01/01/1900	31/12/4999	1
324004400	E080	SICHTFENSTERGRIFF	01/01/1900	31/12/4999	1
719008100	E090	SET-SICHTFENSTERGRIFF	01/01/1900	31/12/4999	1
432003400	E100	SCHRAUBE F.SICHTFENSTERGLAS	01/01/1900	31/12/4999	8
398061800	E110	HALTER FUER SICHTFENSTERGLAS	01/01/1900	31/12/4999	4
432009300	E120	SCHRAUBE FUER SCHARNIER D.SICHTFENSTERS	01/01/1900	31/12/4999	3
432032200	E150	SCHRAUBE F.RUCKZUGFEDER D.KLINKE	01/01/1900	31/12/4999	2
444016100	E160	RUCKZUGFEDER F.KLINKE	01/01/1900	31/12/4999	1
443013500	E200	STIFT FUER TUERVERSCHLUSSHAKEN	01/01/1900	31/12/4999	1

Maschine 010576035 Eudora WAS616

Ersatz.	Pos	Beschreibung	Laufzeit		Men
398245600	E210	TURVERSCHLUSSHAKEN	01/01/1900	31/12/4999	1
444017900	E230	FEDER	01/01/1900	31/12/4999	1
344003500	E250	UNTERRAHMEN F.SICHTFENSTER	01/01/1900	31/12/4999	1
518008100	F010	ELEKTROPUMPE	01/01/1900	31/12/4999	1
402049900	F028	DICHTUNG SICHERUNG ABFLUSSSCHLAUCH	01/01/1900	31/12/4999	1
398260200	F029	KUGEL ABFLUSSMUFFE	01/01/1900	31/12/4999	1
402051100	F031	DICHTUNG ABFLUSSMUFFE	01/01/1900	31/12/4999	1
402049500	F070	KURVE F.ABLAUFBUCHSE	01/01/1900	31/12/4999	1
414004400	F090	SCHLAUCHABLAUF	01/01/1900	31/12/4999	1
440001700	F100	SCHELLE FUR FILTERANSCHLUSS D.PUMPE	01/01/1900	31/12/4999	1
440005300	F110	SCHELLE FUR ABLAUFBUCHSENKURVE	01/01/1900	31/12/4999	1
432007000	F130	SCHRAUBE FUER ELEKTROPUMPE	01/01/1900	31/12/4999	2
398019400	F140	SCHLAUCHKLEMME F.SCHLAUFE D.ABLAUFSCHLAUCHES	01/01/1900	31/12/4999	1
440005400	F150	SCHELLE F.ABFLUSSSCHLAUCH	01/01/1900	31/12/4999	1
414003500	F190	DRUCKWACHTERROHRE	01/01/1900	31/12/4999	1
440000100	F200	DRUCKWACHTERSCHLAUCHSCHELLE MUFFENSEITE	01/01/1900	31/12/4999	1
526021600	G005	THERMOWIDERSTAND	01/01/1900	31/12/4999	1
258002100	G010	QUERSTANGE FUER FEDER	01/01/1900	31/12/4999	1
490012400	G020	GEGENGEWICHT OBEN	01/01/1900	31/12/4999	1
430031100	G029	FESTSTELLSCHRAUBE RIEMENSCHLEIBE ROHRLEITUNG	01/01/1900	31/12/4999	1
398101400	G039	MITNEHMER TROMMEL HERAUSNEHMBAR	01/01/1900	31/12/4999	4
720573800	G077	SCHRAUBE FUER GEGENGEWICHT 9,5X50	01/01/1900	31/12/4999	3
398284100	G078	HALTEBOLZEN STOSSDAEMPFER	01/01/1900	31/12/4999	2
490012500	G080	GEGENGEWICHT UNTEN	01/01/1900	31/12/4999	1
720577500	G093	GESAMTHEIT LAUGENBEHAELTER MIT TROMMEL	01/01/1900	31/12/4999	1
512020900	G130	MOTOR	01/01/1900	31/12/4999	1
524025200	G140	WIDERSTAND	01/01/1900	31/12/4999	1
268117700	G160	RIEMENSCHLEIBE ANTRIEB	01/01/1900	31/12/4999	1
416003200	G170	TREIBRIEMEN	01/01/1900	31/12/4999	1
444024400	G200	AUFHAENGEFEDER BOTTICH	01/01/1900	31/12/4999	2
432035300	G380	SCHRAUBE FUER MOTOR	01/01/1900	31/12/4999	2
499003600	G430	FEDERRING	01/01/1900	31/12/4999	2
432028100	G440	F.FEDERQUERSTUCK	01/01/1900	31/12/4999	4
720573900	G450	SCHRAUBE FUER GEGENGEWICHT UNTEN	01/01/1900	31/12/4999	3
499026300	G690	SCHWINGUNGSDAEPFER	01/01/1900	31/12/4999	2
434004200	G710	BEFESTIGUNGSMUTTER SCHWINGUNGSDAEMPFER	01/01/1900	31/12/4999	2
466000016	LVD008	DOKUMENT TECHNISCHE INFORMATION MAGNETISCHE ENTKALKER	01/01/1900	31/12/4999	1
466000147	LVD035	WARTUNGSHANDBUCH FUER ELEKTRONEN GERAETE	01/01/1900	31/12/4999	1

Maschine **010576035 Eudora WAS616**

Ersatz.	Pos	Beschreibung	Laufzeit		Men
466000065	LVD044	ELEKTRONISCHES WARTUNGSHANDBUCH	01/01/1900	31/12/4999	1
460616184	LVZ000	ELEKTRISCHER SCHALTPLAN	01/01/1900	31/12/4999	1
432035600	Z010	SCHRAUBE F.VERPACKUNG	01/01/1900	12/02/2007	4
432036100	Z010	SCHRAUBE F.VERPACKUNG	12/02/2007	31/12/4999	4
441017600	Z019	BUCHSE FUER DISTANZSTUECK VERPACKUNG	01/01/1900	31/12/4999	4
436006400	Z020	U-SCHEIBE F.SCHRAUBE D.VERPACKUNG	01/01/1900	31/12/4999	4
350009900	Z023	VERSCHLUSS PLASTIKVERPACKUNG	01/01/1900	31/12/4999	4
461306952	Z025	HANDBUCH TECHNISCHE DATEN	01/01/1900	31/12/4999	1
470037700	Z040	DISTANZSTUECK AUS KUNSTSTOFF F.VERPACKUNG	01/01/1900	31/12/4999	4
470055900	Z280	UNTERE VERPACKUNGS-UMHUELLUNG	01/01/1900	31/12/4999	1
470056800	Z290	OBERE VERPACKUNGS-UMHUELLUNG	01/01/1900	31/12/4999	1
476009000	Z300	VORDERES WINKELPROFIL RECHTS-LINKS	01/01/1900	31/12/4999	2
476017100	Z310	HINTERES WINKELPROFIL RECHTS-LINKS	01/01/1900	31/12/4999	2
461306951	Z330	GEBRAUCHSANWEISUNG	01/01/1900	31/12/4999	1